

## FEATURES & BENEFITS

### CONSTRUCTION

FDA approved high-density green polyethylene tank provides the light and durable construction required in a portable unit.

### MOUNTING

J-shaped stainless steel wall bracket makes for a well constructed portable mount for easy removal and re-mount.

### EYEWASH

Pulling down the eyewash arm will begin flushing the 16 gallon portable at .4 gpm (1.5 L) during the required 15 minutes, creating a full patterned flushing of the eyes.

### DESIGN

Tank comes complete with a wide-fill opening and threaded cap for quick inspection, cleaning, and filling. Unit also comes equipped with top and side handles making relocation simple.



## OPTIONS

- ❑ Water Additive: Model 9082, 'sterile' bacteriostatic preservative for use in portable eyewash stations. One 5 oz. (148 ml) bottle will preserve 5 to 20 gallons (18.9 to 75.7 L) of potable water for up to three months. Four bottles per carton.
- ❑ Waste Container: Model 9009 is a twenty gallon (75.7 L) wastewater container constructed of tough yellow polymer resin. Unit is used to collect water during weekly testing of emergency equipment.
- ❑ Thermal Protection Jacket: Model 9125 is a white thermal protection jacket for 7500 series gravity eyewashes.

To see all options for this model, visit [www.hawesco.com](http://www.hawesco.com)

## SPECIFICATIONS

Model 7500 portable gravity operated eyewash shall include a FDA approved high-density green polyethylene 16 gallon (60.6 L) tank, ABS plastic eyewash heads with .4 gpm (1.5 L) flow rate over 15 minutes, yellow pull-down activation arm, integral handles on top and sides, wide-fill threaded cap, label-mounted operation and maintenance instructions, and a stainless steel wall bracket. Additive not included - Order separately.

## APPLICATIONS

Where the eyes of any person may be exposed to injurious or corrosive materials, when suitable facilities for quick flushing of the eyes needs to be provided and a continuous supply of water is not available. Although the 7500 may be installed in a wide variety of locations, it is ideal for the remote and low traffic areas where protective measures are still needed. Emergency eyewash facilities shall be in unobstructed and accessible locations that require no more than 10 seconds for the injured person to reach. Model 7500 is certified by CSA to meet the ANSI Z358.1 Standard for Emergency Eyewash and Shower Equipment.

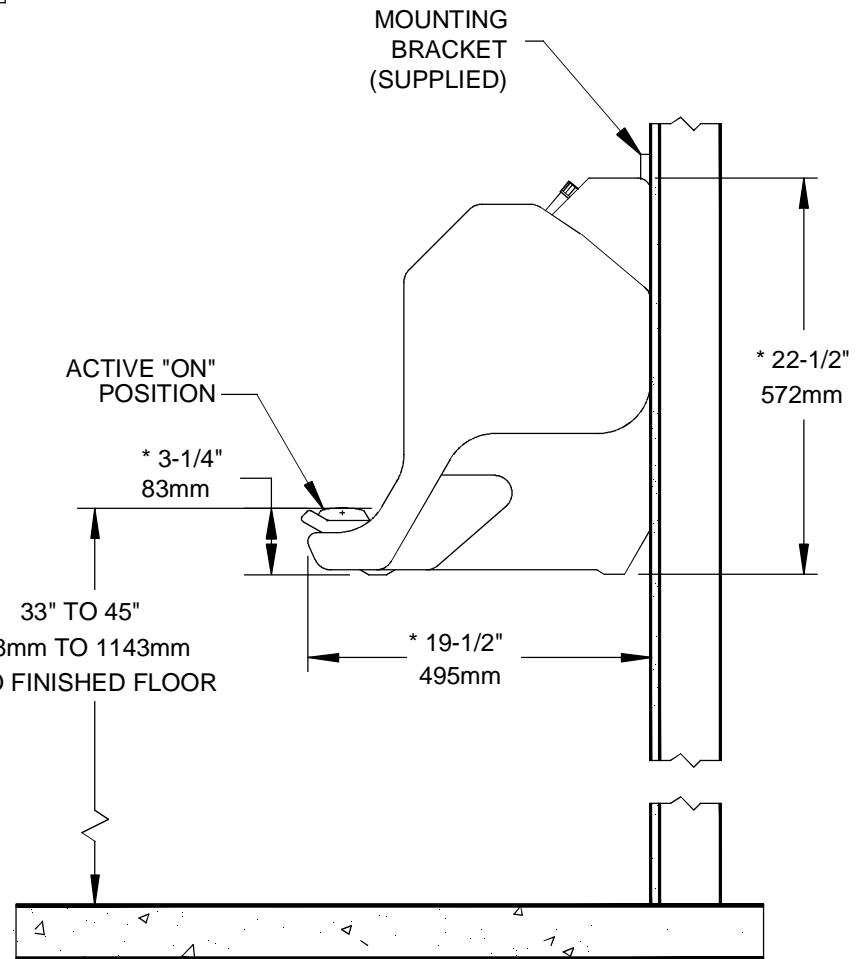
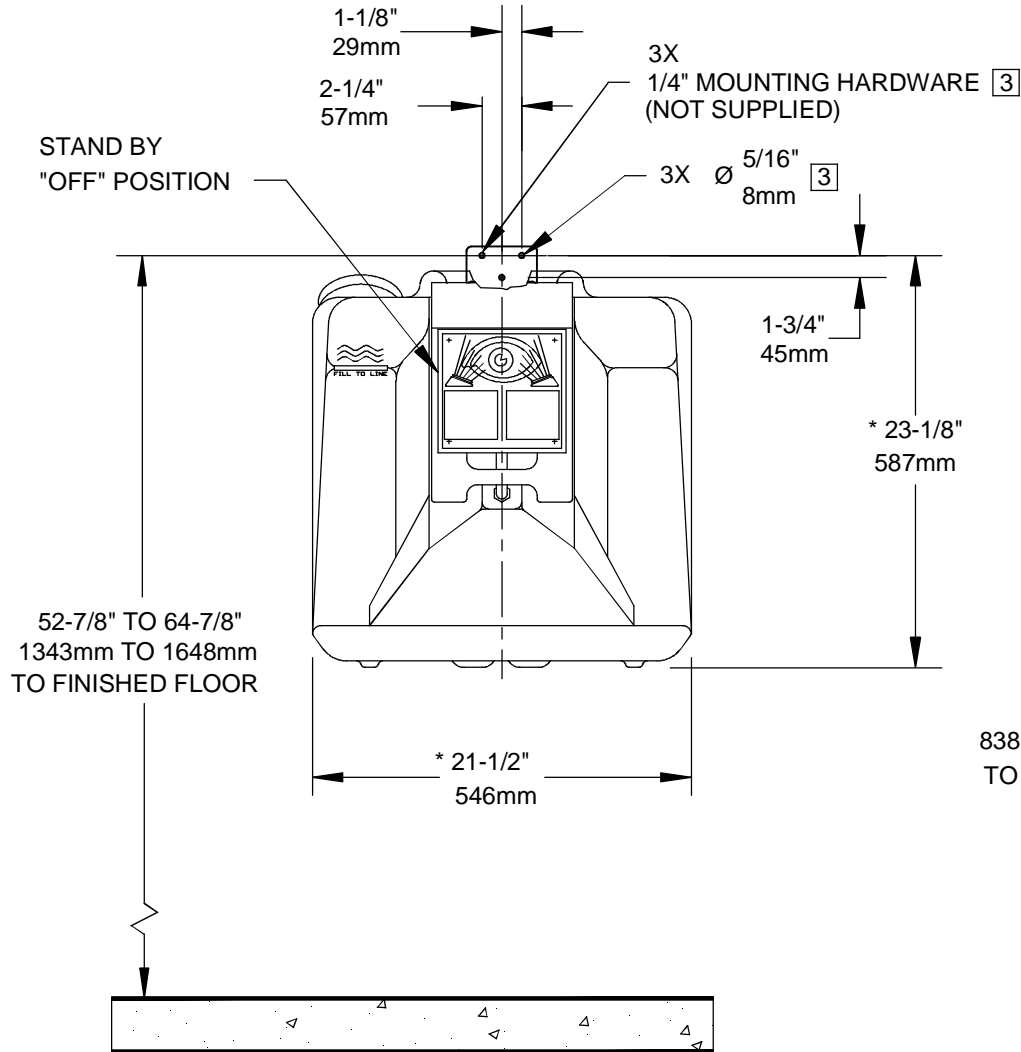

NOTES:

1. TO COMPLY WITH ANSI Z358.1-2009 FOR EMERGENCY EYEWASH OR EYE/FACE WASH AND SHOWER EQUIPMENT:
  - UNIT SHALL BE INSTALLED IN ACCORDANCE WITH MANUFACTURER'S INSTRUCTIONS AND ACCEPTABLE PLUMBING PRACTICES.
  - EYEWASH OR EYE/FACE WASH SHALL BE POSITIONED WITH NOZZLES NOT LESS THEN 83.8 CM (33 IN.) AND NO GREATER THAN 114.3 CM (45 IN.) FROM SURFACE ON WHICH USER STANDS AND 15.3 CM (6 IN.) MINIMUM FROM WALL OR NEAREST OBSTRUCTION.
2. UNIT MUST BE LEVEL FROM FRONT TO BACK AND SIDE TO SIDE.
3. ALL THREE MOUNTING HOLES ON MOUNTING-BRACKET MUST BE USED TO PROPERLY SECURE EYEWASH UNIT TO WALL.
4. \*DIMENSIONS MAY VARY ±1/2" [12.7mm]

		1455 KLEPPE LANE SPARKS, NEVADA 89431 (775) 359-4712 FAX (755) 359-7424 E-MAIL: HAWS@HAWSO.COM WEBSITE: WWW.HAWSO.COM	
		ECN NO. REVISED PER BY: MODEL(S) ECN: 4672 PF:	7500 PORTABLE EYEWASH
DRAWN: C.H. DATE: 05/21/91 APPROVED:	DATE:	CHKD:	DRAWING NO. REV 09655A00 16
SCALE: 1:10		DRAWING TYPE: INSTALLATION	SIZE: A SHEET 1 OF 1

ITEM	DESCRIPTION	PART NO.
1	EYEWASH HEAD ASSEMBLY	SP19
2	BRACKET	0001217418
3	CAP	SP131
4	STERILE ANTIMICROBIAL PRESERVATIVE	9082

# PARTS BREAKDOWN

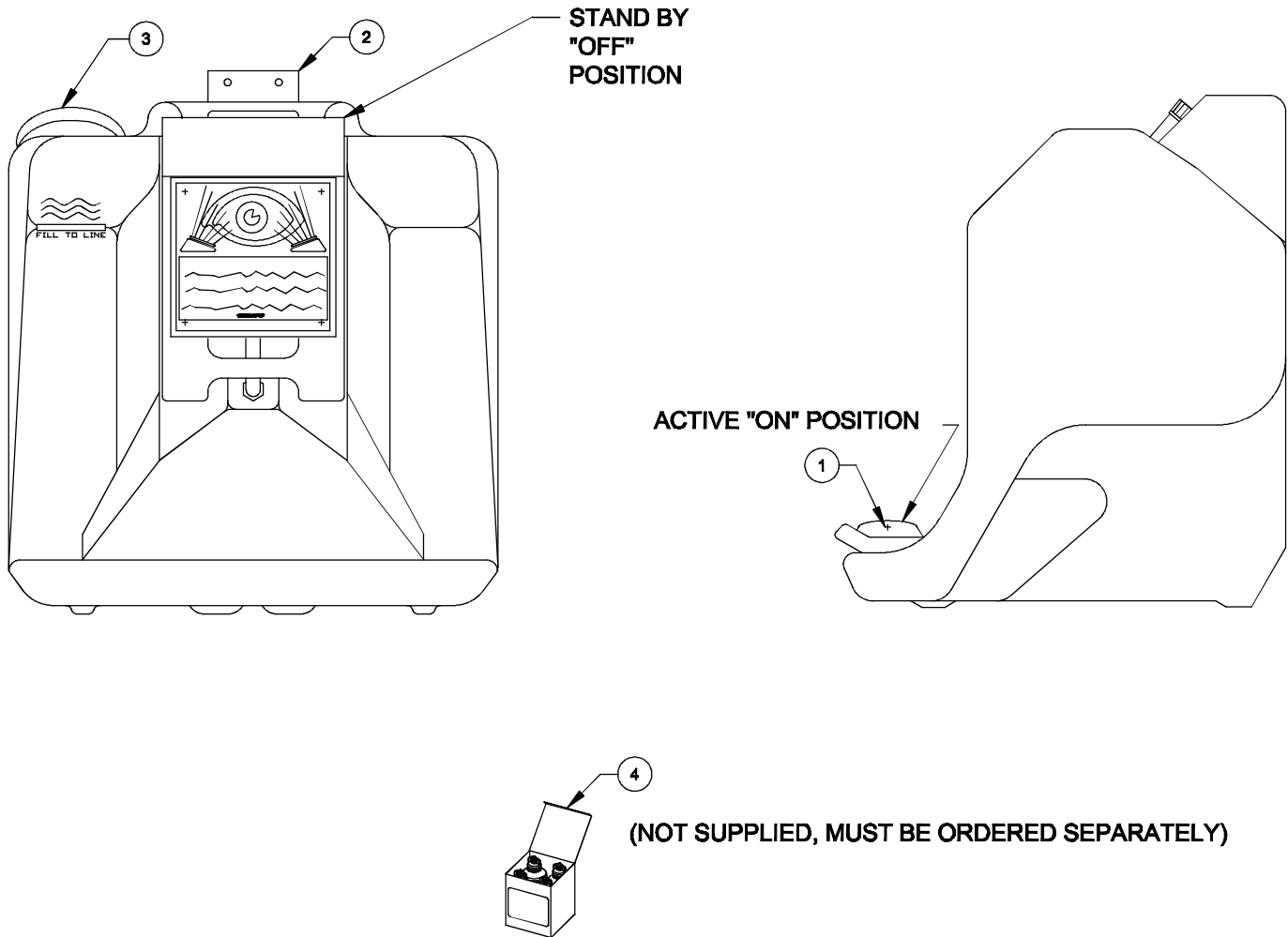

 <b>Haws</b> <sup>®</sup>		1455 KLEPPE LANE SPARKS, NEVADA 89431 (775) 359-4712 FAX (775) 359-7424 E-MAIL: HAWS@HAWSCO.COM WEBSITE: WWW.HAWSCO.COM	
		ECN NO. REVISED PER BY ECN: 4742 HM	MODEL(S) <b>7500</b> <b>PORTABLE EYEWASH</b>
DRAWN CLF DATE 08/24/83	APPROVED DATE	DRAWING NO. <b>11454C00</b>	REV <b>17</b>
SCALE: 1/4   DRAWING TYPE: PARTS BREAKDOWN		SIZE: A SHEET 1 OF 1	

WHEN ORDERING PARTS PLEASE SPECIFY MODEL NUMBER.